

Gamma and X-Ray Standards



A wide range of gamma and x-ray standards for research and educational use are available in the energy range of 5.9 to 2614 keV. Many nuclides are available up to 100 μCi (3.7 MBq) to allow for the lower efficiencies of detection inherent in many instruments. Available activity ranges are listed for each nuclide in the tables on pages 46 to 53. Please contact customer service for other activity requirements.

Gamma Standards—Type C

The type C configuration can be used to check the performance of G.M. and NaI (Tl) detectors. The maximum activity of this source type is 10 μCi (370 kBq). Please call customer service for a quotation.

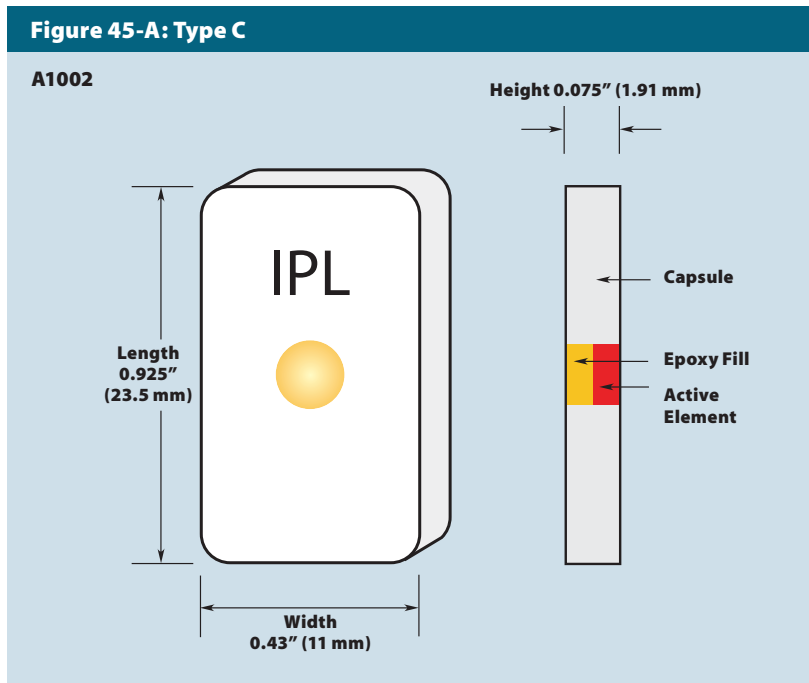

Overall Dimensions			
Height	Width	Length	Active Diameter
0.075"	0.43"	0.925"	0.118"
1.91 mm	11 mm	23.5 mm	3 mm

Window & Active Deposit	
Window	Nature of Active Deposit
Plastic	Evaporated Metallic Salts

Simulated I-125 Sources										
<p>I-129 sources are frequently referred to as "simulated I-125 sources." I-129 does not in fact simulate I-125 well enough to use it to calibrate an I-125 counter. The equivalence of I-129 to I-125 will vary from one counter to another due to the differing photon energies and counting geometries. EZIP recommends the purchase of an I-125 standard for the initial instrument calibration. An I-129 source may then be used for a daily check of instrument response.</p>	<p>The energies and abundances of I-125 and I-129 x-rays and photons are:</p>									
		<table border="1"> <thead> <tr> <th></th> <th>K x-rays (keV)</th> <th>Gammas (keV)</th> </tr> </thead> <tbody> <tr> <td>I-125</td> <td>(Te) 27-32 (141%)</td> <td>35.5 (6.66%)</td> </tr> <tr> <td>I-129</td> <td>(Xe) 29-35 (70.8%)</td> <td>39.6 (7.5%)</td> </tr> </tbody> </table>		K x-rays (keV)	Gammas (keV)	I-125	(Te) 27-32 (141%)	35.5 (6.66%)	I-129	(Xe) 29-35 (70.8%)
	K x-rays (keV)	Gammas (keV)								
I-125	(Te) 27-32 (141%)	35.5 (6.66%)								
I-129	(Xe) 29-35 (70.8%)	39.6 (7.5%)								

Gamma and X-Ray Standards

Gamma Standards—Type D

The type D configuration is mainly used for checking the performance of G.M. and NaI(Tl) detectors. The type D disk is a 1" (25.4 mm) diameter by 0.250" (6.35 mm) thick disk constructed of high strength plastic. The active diameter is 0.197" (5 mm).



Figure 46-A: Type D Disk

A1001

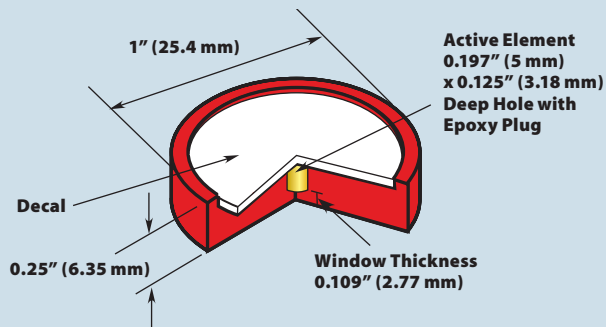

Overall Dimensions

Overall Diameter	Active Diameter	Height
1"	0.197"	0.25"
25.4 mm	5 mm	6.35 mm

Window & Active Deposit

Window	Nature of Active Deposit
Plastic	Evaporated Metallic Salts

Gamma Standards—Type D

Catalog Number	Nuclide	Half-Life	Major Photon Emissions (keV)	Available Activities
GF-241-D	Americium-241	432.17 y	59.5 (36%), 11-20 (39.5%) Np L x-rays	5 nCi-100 µCi 185 Bq-3.7 MBq
GF-124-D	Antimony-124	60.20 d	602.7 (97.9%), 722.8 (10.9%), 1690.9 (47.6%)	5 nCi-100 µCi 185 Bq-3.7 MBq
GF-125A-D	Antimony-125	1007.7 d	428 (29.7%), 464 (10.5%), 601 (17.7%), 607 (5%), 636 (11.2%), 27-32 (75.1%) Te K x-rays	5 nCi-100 µCi 185 Bq-3.7 MBq
GF-133-D	Barium-133	3862 d	80 (34.1%), 303 (18.3%), 356 (61.9%), 32-37 (53.2%) Cs K x-rays	5 nCi-100 µCi 185 Bq-3.7 MBq
GF-007-D	Beryllium-7	53.284 d	478 (10.3%)	25 nCi-500 µCi 925 Bq-18.5 MBq
GF-207-D	Bismuth-207	1.16 x 10 ⁴ d	570 (97.7%), 1064 (74.5%), 9-15 (32.5%), Pb L x-rays, 72-88 (77.7%) Pb K x-rays	5 nCi-100 µCi 185 Bq-3.7 MBq
GF-109-D	Cadmium-109	462.6 d	88 (3.6% from Ag-109m), 22-26 (99.4%) Ag K x-rays	50 nCi-1 mCi 1.85 kBq-37 MBq
GF-139-D	Cerium-139	137.640 d	33.03 (22.8%), 33.4 (41.9%), 165.9 (79.9%), 33-39 (80%) La x-rays	5 nCi-10 µCi 185 Bq-370 kBq
GF-141-D	Cerium-141	On Request	—	—
GF-134-D	Cesium-134	754.28 d	563 (8.4%), 569 (15.4%), 605 (97.6%), 796 (85.4%)	5 nCi-100 µCi 185 Bq-3.7 MBq
GF-137-D	Cesium-137	30.17 y	662 (85.1% from Ba-137), 32-37 (7.2%) Ba K x-rays	5 nCi-1 mCi 185 Bq-3.7 MBq
GF-051-D	Chromium-51	27.706 d	320 (9.86%), 4.9-5.4 (22.8%) V K x-rays	25 nCi-500 µCi 185 Bq-37 MBq

Gamma Standards—Type D

Catalog Number	Nuclide	Half-Life	Major Photon Emissions (keV)	Available Activities
GF-056-D	Cobalt-56	77.31 d	846.8 (99.9%), 1238 (66.1%), 1771 (15.5%), 2035 (7.8%), 2598 (17%), 3253 (7.6%), others up to 3452	10 nCi-100 µCi 370 Bq-3.7 MBq
GF-057-D	Cobalt-57	271.79 d	14 (9.2%), 122 (85.6%), 136.5 (10.7%), 6.4-7.1 (57.9%) Fe K x-rays	5 nCi-1 mCi 185 Bq-37 MBq
GF-058-D	Cobalt-58	70.86 d	810 (99.5%), 6.4-7.1 (26.7%) Fe K x-rays	5 nCi-100 µCi 185 Bq-3.7 MBq
GF-060-D	Cobalt-60	5.272 y	1173 (100%), 1333 (100%)	5 nCi-1 mCi 185 Bq-37 MBq
GF-152-D	Europium-152	4933 d	122-1408, 40-47 (74%) Sm + Gd x-rays	25 nCi-100 µCi 925 Bq-3.7 MBq
GF-154-D	Europium-154	3136.8 d	123-1597, 42-50 (25.6%) Gd x-rays	25 nCi-100 µCi 925 Bq-3.7 MBq
GF-155-D	Europium-155	1770 d	87 (34%), 105 (20.6%), 42-50 (24.0%), Gd K x-rays	10 nCi-100 µCi 370 Bq-3.7 MBq
GF-153-D	Gadolinium-153	242 d	97 (29.5%), 103 (21.1%), 40-49 (122%) Eu K x-rays	5 nCi-1 mCi 185 Bq-37 MBq
GF-068-D	Germanium-68	270.8 d	511 (178%), 1077 (3.2%) from Ga-68, 9.2-10.4 (44.1%) Ga K x-rays, 8.6-9.6 (4.7%) Zn K x-rays	100 nCi-100 µCi 3.7 kBq-3.7 MBq
GF-166-D	Holmium-166m ⁽¹⁾	1200 y	81-1427, 48-58 (37.6%) Er K x-rays	10 nCi-10 µCi 370 Bq-370 kBq
GF-125-D	Iodine-125	59.43 d	35 (6.58%), 27-32 (139%) Te K x-rays	10 nCi-100 µCi 370 Bq-3.7 MBq
GF-129-D	Iodine-129	1.57 x 10 ⁷ y	40 (7.5%), 29-35 (70.4%) Xe K x-rays	50 nCi-1 µCi 1.85 kBq-37 kBq
GF-059-D	Iron-59	44.51 d	1099 (56.3%), 1292 (43.7%)	5 nCi-100 µCi 185 Bq-3.7 MBq
GF-054-D	Manganese-54	312.3 d	835 (100%), 5.4-5.9 (25.6%) Cr K x-rays	5 nCi-100 µCi 185 Bq-3.7 MBq
GF-203-D	Mercury-203	46.595 d	279.2 (81.5%)	10 nCi-50 µCi 370 Bq-1.85 MBq
GF-226-D	Radium-226	1600 y	47-2448 (includes daughters)	50 nCi-10 µCi 1.85 kBq-370 kBq
GF-106-D	Ruthenium-106	1.020 y	512 (20.7%), 622 (9.8%) from Rh-106	25 nCi-100 µCi 925 Bq-3.7 MBq
GF-046-D	Scandium-46	83.79 d	889 (99.9%), 1121 (99.9%)	5 nCi-100 µCi 185 Bq-3.7 MBq
GF-075-D	Selenium-75	119.64 d	121 (17.1%), 136 (58.8%), 265 (59%), 280 (25%), 10.5-12.0 (56.8%) As K x-rays	5 nCi-100 µCi 185 Bq-3.7 MBq
GF-110-D	Silver-110m	249.8 d	657.8 (94.4%), 884.6 (72.6%)	5 nCi-50 µCi 185 Bq-1.85 MBq
GF-131-D	Simulated I-131	~5 y	356 (from Ba-133), 662 (from Cs-137/Ba-137)	50 nCi-100 µCi 1.85 kBq-3.7 MBq
GF-022-D	Sodium-22	950.8 d	511 (178%), 1275 (100%)	5 nCi-100 µCi 185 Bq-3.7 MBq
GF-085-D	Strontium-85	64.849 d	514 (98.4%), 13.3-15.3 (58.7%) Rb K x-rays	5 nCi-100 µCi 185 Bq-3.7 MBq
GF-228-D	Thorium-228	698.2 d	84-2614 (includes daughters)	10 nCi-10 µCi 370 Bq-370 kBq
GF-113-D	Tin-113	115.09 d	392 (64% from In-113 m), 24-28 (96.8%) In K x-rays	5 nCi-100 µCi 185 Bq-3.7 MBq
GF-235-D	Uranium-235 ⁽¹⁾	7.037 x 10 ⁸ y	143 (10.5%), 186 (53%), 90-105 (10.8%) Th K x-rays	10 nCi-100 nCi 370 Bq-3.7 kBq
GF-238U-D	Uranium (Natural) ⁽¹⁾	4.468 x 10 ⁹ y	26-2448 (includes daughters)	10 nCi-100 nCi 370 Bq-3.7 kBq
GF-088-D	Yttrium-88	106.630 d	898 (94%), 1836 (99.4%), 14.1-16.2 (61.6%) Sr K x-rays	5 nCi-100 µCi 185 Bq-3.7 MBq
GF-065-D	Zinc-65	244.26 d	1116 (50.6%), 8.0-8.9 (38.7%) Cu K x-rays	5 nCi-100 µCi 185 Bq-3.7 MBq
GF-095-D	Zirconium-95/Nb-95	64.02 d	724 (44.1%), 757 (54.5%)	10 nCi-50 µCi 370 Bq-1.85 MBq

1) 9 mm active diameter.

Gamma Sets—Type D

Catalog Number	Available Activities	Sets Consist Of
GF-290-0.1D	0.1 µCi 3.7 kBq	Ba-133, Cd-109, Co-57, Co-60, Cs-137, Mn-54 and Na-22
GF-290-1D	1 µCi 37 kBq	Ba-133, Cd-109, Co-57, Co-60, Cs-137, Mn-54 and Na-22
GF-290-10D	10 µCi 370 kBq	Ba-133, Cd-109, Co-57, Co-60, Cs-137, Mn-54 and Na-22

Gamma and X-Ray Standards

Gamma Standards—Type M

The type M thin “scatterless” disk is used in applications involving high resolution solid state detectors. The activity is deposited on 9 mg/cm² aluminumized Mylar (polyester) disk, and covered with 0.9 mg/cm² Kapton (polyimide). The source is supplied in a removable aluminum holder. In the holder the source has an overall diameter of 1” (25.4 mm) and a thickness of 0.125” (3.18 mm). Out of the holder the source is 0.937” (23.8 mm) in diameter with a thickness of approximately 0.030” (0.76 mm). The active diameter is 0.12” (3 mm).



Figure 48-A: Type M Disk

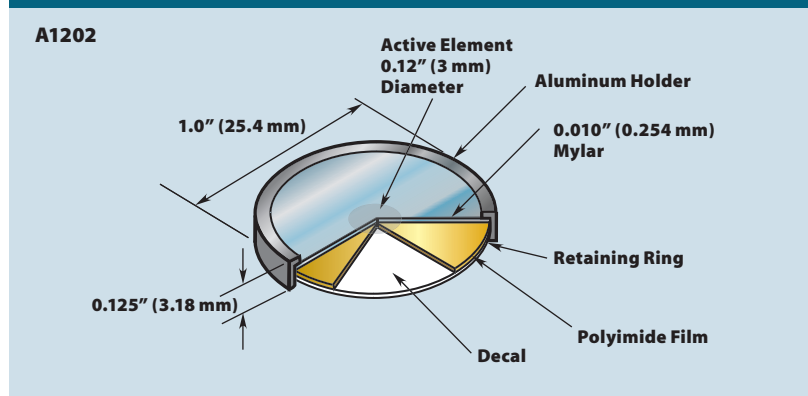

Overall Dimensions

Overall Diameter	Active Diameter	Height
1"	0.12"	0.125"
25.4 mm	3 mm	3.18 mm

Window

0.010" (0.254 mm)
Aluminized Mylar

Nature of Active Deposit

Evaporated
Metallic Salts

Exceptions

Fe-55: 0.00025" (0.0064 mm) Aluminized Mylar
Am-241: 0.001" (0.0254 mm) Aluminum and Platinum Foils

Gamma Standards—Type M

Catalog Number	Nuclide	Half-Life	Major Photon Emissions (keV)	Available Activities
GF-241-M	Americium-241	432.17 y	59.5(36%), 11-20(39.5%) Np L x-rays	5 nCi-10 µCi 185 Bq-370 kBq
GF-124-M	Antimony-124	60.20 d	602.7(97.9%), 722.8(10.9%), 1690.9(47.6%)	5 nCi-100 µCi 185 Bq-3.7 MBq
GF-125A-M	Antimony-125A	1007.7 d	428(29.7%), 464(10.5%), 601(17.7%), 607(5%), 636(11.2%), 27-32(75.1%) Te K x-rays	5 nCi-100 µCi 185 Bq-3.7 MBq
GF-133-M	Barium-133	3862 d	80(34.1%), 303(18.3%), 356(61.9%), 32-37(53.2%) Cs K x-rays	5 nCi-100 µCi 185 Bq-3.7 MBq
GF-007-M	Beryllium-7	53.28 d	478(10.3%)	25 nCi-500 µCi 925 Bq-18.5 MBq
GF-207-M	Bismuth-207	1.16 x 10 ⁴ d	570(97.7%), 1064(74.5%), 9-15(32.5%), Pb L x-rays, 72-88(77.7%) Pb K x-rays	5 nCi-100 µCi 185 Bq-3.7 MBq
GF-109-M	Cadmium-109	462.6 d	88(3.6% from Ag-109 m), 22-26(99.4%) Ag K x-rays	50 nCi-100 µCi 1.85 kBq-3.7 MBq
GF-139-M	Cerium-139	137.640 d	33.03(22.8%), 33.4(41.9%), 165.9(79.9%), 33-39(80%) La x-rays	50 nCi-1 µCi 1.85 kBq-37 kBq
GF-141-M	Cerium-141	32.5 d	36.0(9.1%), 35.6(5%), 145.4(48.4%), 352.42(17%), Pr x-rays	On Request —
GF-134-M	Cesium-134	754.28 d	563(8.4%), 569(15.4%), 605(97.6%), 796(85.4%)	5 nCi-100 µCi 185 Bq-3.7 MBq
GF-137-M	Cesium-137	30.17 y	662(85.1% from Ba-137), 32-37(7.2%) Ba K x-rays	5 nCi-100 µCi 185 Bq-3.7 MBq
GF-051-M	Chromium-51	27.706 d	320(9.86%), 4.9-5.4(22.8%) V K x-rays	25 nCi-100 µCi 925 Bq-3.7 MBq

Gamma Standards—Type M						
Catalog Number	Nuclide	Half-Life	Major Photon Emmissions (keV)	Available Activities		
GF-056-M	Cobalt-56	77.31 d	846.8(99.9%), 1238(66.1%), 1771(15.5%), 2035(7.8%), 2598(17%), 3253(7.6%), others up to 3452	10 nCi-100 µCi	370 Bq-3.7 MBq	
GF-057-M	Cobalt-57	271.79 d	14(9.2%), 122(85.6%), 136.5(10.7%), 6.4-7.1(57.9%) Fe K x-rays	5 nCi-100 µCi	185 Bq-3.7 MBq	
GF-058-M	Cobalt-58	70.86 d	810(99.5%), 6.4-7.1(26.7%) Fe K x-rays	5 nCi-100 µCi	185 Bq-3.7 MBq	
GF-060-M	Cobalt-60	5.272 y	1173(100%), 1333(100%)	5 nCi-100 µCi	185 Bq-3.7 MBq	
GF-152-M	Europium-152	4933 d	122-1408, 40-47(74%) Sm +Gd x-rays	25 nCi-100 µCi	925 Bq-3.7 MBq	
GF-154-M	Europium-154	3136.8 d	123-1597, 42-50(25.6%) Gd x-rays	25 nCi-100 µCi	925 Bq-3.7 MBq	
GF-155-M	Europium-155	1770 d	87(34%), 105(20.6%), 42-50(24.0%), Gd K x-rays	10 nCi-100 µCi	370 Bq-3.7 MBq	
GF-153-M	Gadolinium-153	242 d	97(29.5%), 103(21.1%), 40-49(122%) Eu K x-rays	10 nCi-100 µCi	370 Bq-3.7 MBq	
GF-068-M	Germanium-68	270.8 d	511(178%), 1077(3.2%) from Ga-68, 9.2-10.4(44.1%) Ga K x-rays, 8.6-9.6(4.7%) Zn K x-rays	100 nCi-100 µCi	3.7 kBq-3.7 MBq	
GF-166-M	Holmium-166m	1200 y	81-1427, 48-58(37.6%) Er K x-rays	10 nCi-1 µCi	370 Bq-37 kBq	
GF-055-M	Iron-55	999 d	5.8-6.5(27.3%) Mn K x-rays	1 µCi-100 µCi	37 kBq-3.7 MBq	
GF-059-M	Iron-59	44.51 d	1099(56.3%), 1292(43.7%)	5 nCi-100 µCi	185 Bq-3.7 MBq	
GF-054-M	Manganese-54	312.3 d	835(100%), 5.4-5.9(25.6%) Cr K x-rays	5 nCi-100 µCi	185 Bq-3.7 MBq	
GF-203-M	Mercury-203	46.595 d	279.2(81.5%)	10 nCi-10 µCi	370 Bq-370 kBq	
GF-046-M	Scandium-46	83.79 d	889(99.9%), 1121(99.9%)	5 nCi-100 µCi	185 Bq-3.7 MBq	
GF-075-M	Selenium-75	119.64 d	121(17.1%), 136(58.8%), 265(59%), 280(25%), 10.5-12.0(56.8%) As K x-rays	5 nCi-100 µCi	185 Bq-3.7 MBq	
GF-110-M	Silver-110m	249.8 d	657.8(94.4%), 884.6(72.6%)	5 nCi-50 µCi	185 Bq-1.85 MBq	
GF-131-M	Simulated I-131	~5 y	356(from Ba-133), 662(from Cs-137/Ba-137)	50 nCi-100 µCi	1.85 kBq-3.7 MBq	
GF-022-M	Sodium-22	950.8 d	511(178%), 1275(100%)	5 nCi-100 µCi	185 Bq-3.7 MBq	
GF-085-M	Strontium-85	64.849 d	514(98.4%), 13.3-15.3(58.7%) Rb K x-rays	5 nCi-100 µCi	185 Bq-3.7 MBq	
GF-113-M	Tin-113	115.09 d	392(64% from In-113 m), 24-28(96.8%) In K x-rays	5 nCi-10 µCi	185 Bq-370 kBq	
GF-088-M	Yttrium-88	106.630 d	898(94%), 1836(99.4%), 14.1-16.2(61.6%) Sr K x-rays	5 nCi-100 µCi	185 Bq-3.7 MBq	
GF-065-M	Zinc-65	244.26 d	1116(50.6%), 8.0-8.9(38.7%) Cu K x-rays	5 nCi-100 µCi	185 Bq-3.7 MBq	
GF-095-M	Zirconium-95/Nb-95	64.02 d	724(44.1%), 757(54.5%)	10 nCi-50 µCi	370 Bq-1.85 MBq	

Gamma Sets—Type M			
Catalog Number	Available Activities		Sets Consist Of
GF-290-0.1M	0.1 µCi	3.7 kBq	Ba-133, Cd-109, Co-57, Co-60, Cs-137, Mn-54 and Na-22
GF-290-1M	1 µCi	37 kBq	Ba-133, Cd-109, Co-57, Co-60, Cs-137, Mn-54 and Na-22
GF-290-10M	10 µCi	370 kBq	Ba-133, Cd-109, Co-57, Co-60, Cs-137, Mn-54 and Na-22

Gamma and X-Ray Standards

Gamma Standards—Type R

The type R rod is used for calibrating well type NaI(Tl) detectors. It is constructed of high strength plastic and is offered in three sizes: 5" high x 0.625" diameter (127 mm x 15.9 mm), 5" high x 0.5" diameter (127 mm x 12.7 mm) and 2.95" x 0.5" diameter (74.9 mm x 12.7 mm). The active diameter of the rod standard is 0.187" (4.75 mm).



Window & Active Materials	
Window	Nature of Active Materials
Plastic	Evaporated Metallic Salts

Overall Dimensions				
Assembly	X	Height	Diameter	Active Diameter
A1100	R1	5" (127 mm)	0.625" (15.9 mm)	0.187" (4.75 mm)
A1102	R2	5" (127 mm)	0.5" (12.7 mm)	0.187" (4.75 mm)
A1103	R3	2.95" (74.9 mm)	0.5" (12.7 mm)	0.187" (4.75 mm)

Figure 50-A: Type R Rod

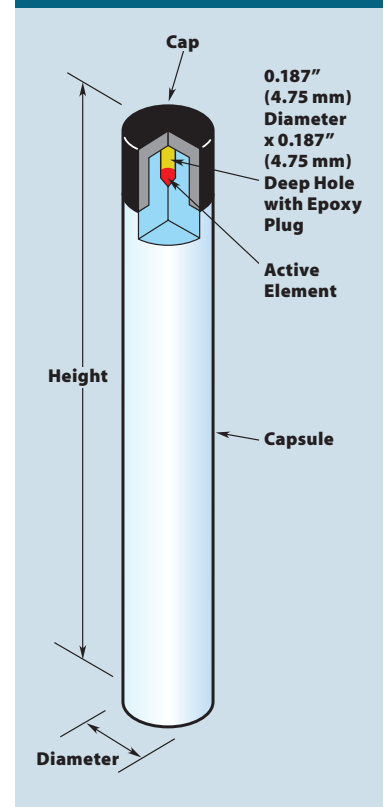

Gamma Standards—Type R					
Catalog Number	Nuclide	Half-Life	Major Photon Emissions (keV)	Available Activities	
GF-241-x	Americium-241	432.17 y	59.5 (36%), 11-20 (39.5%) Np L x-rays	5 nCi-100 µCi	185 Bq-3.7 MBq
GF-124-x	Antimony-124	60.20 d	602.7(97.9%), 722.8(10.9%), 1690.9(47.6%)	5 nCi-100 µCi	185 Bq-3.7 MBq
GF-125A-x	Antimony-125A	1007.7 d	428(29.7%), 464(10.5%), 601(17.7%), 607(5%), 636(11.2%), 27-32(75.1%) Te K x-rays	5 nCi-100 µCi	185 Bq-3.7 MBq
GF-133-x	Barium-133	3862 d	80(34.1%), 303(18.3%), 356(61.9%), 32-37(53.2%) Cs K x-rays	5 nCi-100 µCi	185 Bq-3.7 MBq
GF-007-x	Beryllium-7	On Request			
GF-207-x	Bismuth-207	1.16 x 10 ⁴ d	570(97.7%), 1064(74.5%), 9-15(32.5%), Pb L x-rays, 72-88(77.7%) Pb K x-rays	5 nCi-100 µCi	185 Bq-3.7 MBq
GF-109-x	Cadmium-109	462.6 d	88(3.6% from Ag-109 m), 22-26(99.4%) Ag K x-rays	50 nCi-1 mCi	1.85 kBq-37 MBq
GF-139-x	Cerium-139	137.640 d	33.03(22.8%), 33.4(41.9%), 165.9(79.9%), 33-39(80%) La x-rays	5 nCi-10 µCi	185 Bq-370 kBq
GF-141-x	Cerium-141	32.5 d	36.0 (9.1%), 35.6 (5%), 145.4 (48.4%), 352.42 (17%), Pr x-rays	On Request	—
GF-134-x	Cesium-134	754.28 d	563(8.4%), 569(15.4%), 605(97.6%), 796(85.4%)	5 nCi-100 µCi	185 Bq-3.7 MBq
GF-137-x	Cesium-137	30.17 y	662(85.1% from Ba-137), 32-37(7.2%) Ba K x-rays	5 nCi-1 mCi	185 Bq-37 MBq
GF-051-x	Chromium-51	27.706 d	320(9.86%), 4.9-5.4(22.8%) V K x-rays	25 nCi-500 µCi	925 Bq-18.5 MBq

Gamma Standards—Type R						
Catalog Number	Nuclide	Half-Life	Major Photon Emmissions (keV)	Available Activities		
GF-056-x	Cobalt-56	77.31 d	846.8(99.9%), 1238(66.1%), 1771(15.5%), 2035(7.8%), 2598(17%), 3253(7.6%), others up to 3452	10 nCi-100 µCi	370 Bq-3.7 MBq	
GF-057-x	Cobalt-57	271.79 d	14(9.2%), 122(85.6%), 136.5(10.7%), 6.4-7.1(57.9%) Fe K x-rays	5 nCi-100 µCi	185 Bq-3.7 MBq	
GF-058-x	Cobalt-58	70.86 d	810(99.5%), 6.4-7.1(26.7%) Fe K x-rays	5 nCi-100 µCi	185 Bq-3.7 MBq	
GF-060-x	Cobalt-60	5.272 y	1173(100%), 1333(100%)	5 nCi-100 µCi	185 Bq-3.7 MBq	
GF-152-x	Europium-152	4933 d	122-1408, 40-47(74%) Sm +Gd x-rays	25 nCi-100 µCi	925 Bq-3.7 MBq	
GF-154-x	Europium-154	3136.8 d	123-1597, 42-50(25.6%) Gd x-rays	25 nCi-100 µCi	925 Bq-3.7 MBq	
GF-155-x	Europium-155	1770 d	87(34%), 105(20.6%), 42-50(24.0%), Gd K x-rays	10 nCi-100 µCi	370 Bq-3.7 MBq	
GF-153-x	Gadolinium-153	242 d	97(29.5%), 103(21.1%), 40-49(122%) Eu K x-rays	10 nCi-100 µCi	370 Bq-3.7 MBq	
GF-068-x	Germanium-68	270.8 d	511(178%), 1077(3.2%) from Ga-68, 9.2-10.4(44.1%) Ga K x-rays, 8.6-9.6(4.7%) Zn K x-rays	100 nCi-100 µCi	3.7 kBq-3.7 MBq	
GF-166-x	Holmium-166m	1200 y	81-1427, 48-58(37.6%) Er K x-rays	10 nCi-10 µCi	370 Bq-370 kBq	
GF-125-x	Iodine-125	59.43 d	35(6.58%), 27-32(139%) Te K x-rays	10 nCi-10 µCi	370 Bq-370 kBq	
GF-129-x	Iodine-129	1.57 x 10 ⁷ y	40(7.5%), 29-35(70.4%) Xe K x-rays	50 nCi-1 µCi	1.85 kBq-37 kBq	
GF-059-x	Iron-59	44.51 d	1099(56.3%), 1292(43.7%)	5 nCi-100 µCi	185 Bq-3.7 MBq	
GF-054-x	Manganese-54	312.3 d	835(100%), 5.4-5.9(25.6%) Cr K x-rays	5 nCi-100 µCi	185 Bq-3.7 MBq	
GF-203-x	Mercury-203	46.595 d	279.2(81.5%)	10 nCi-50 µCi	370 Bq-1.85 MBq	
GF-226-x	Radium-226	1600 y	47-2448 (includes daughters)	50 nCi-10 µCi	1.85 kBq-370 kBq	
GF-106-x	Ruthenium-106	1.020 y	512(20.7%), 622(9.8%) from Rh-106	25 nCi-100 µCi	925 Bq-3.7 MBq	
GF-046-x	Scandium-46	83.79 d	889(99.9%), 1121(99.9%)	5 nCi-100 µCi	185 Bq-3.7 MBq	
GF-075-x	Selenium-75	119.64 d	121(17.1%), 136(58.8%), 265(59%), 280(25%), 10.5-12.0(56.8%) As K x-rays	5 nCi-100 µCi	185 Bq-3.7 MBq	
GF-110-x	Silver-110m	249.8 d	657.8(94.4%), 884.6(72.6%)	5 nCi-50 µCi	185 Bq-1.85 MBq	
GF-131-x	Simulated I-131	~5 y	356(from Ba-133), 662(from Cs-137/Ba-137)	50 nCi-100 µCi	1.85 kBq-3.7 MBq	
GF-022-x	Sodium-22	950.8 d	511(178%), 1275(100%)	5 nCi-100 µCi	185 Bq-3.7 MBq	
GF-085-x	Strontium-85	64.849 d	514(98.4%), 13.3-15.3(58.7%) Rb K x-rays	5 nCi-100 µCi	185 Bq-3.7 MBq	
GF-228-x	Thorium-228	698.2 d	84-2614 (includes daughters)	50 nCi-10 µCi	1.85 kBq-370 kBq	
GF-113-x	Tin-113	115.09 d	392(64% from In-113 m), 24-28(96.8%) In K x-rays	5 nCi-100 µCi	185 Bq-3.7 MBq	
GF-235-x	Uranium-235	7.037 x 10 ⁸ y	143(10.5%), 186(53%), 90-105(10.8%) Th K x-rays	10 nCi-100 nCi	370 Bq-3.7 kBq	
GF-238U-x	Uranium (Natural)	4.468 x 10 ⁹ y	26-2448 (includes daughters)	10 nCi-35 nCi	370 Bq-1.29 kBq	
GF-088-x	Yttrium-88	106.630 d	898(94%), 1836(99.4%), 14.1-16.2(61.6%) Sr K x-rays	5 nCi-100 µCi	185 Bq-3.7 MBq	
GF-065-x	Zinc-65	244.26 d	1116(50.6%), 8.0-8.9(38.7%) Cu K x-rays	5 nCi-100 µCi	185 Bq-3.7 MBq	
GF-095-x	Zirconium-95/Nb-95	64.02 d	724(44.1%), 757(54.5%)	10 nCi-50 µCi	370 Bq-1.85 MBq	

Gamma Sets—Type R			
Catalog Number	Available Activities		Sets Consist Of
GF-290-0.1x	0.1 µCi	3.7 kBq	Ba-133, Cd-109, Co-57, Co-60, Cs-137, Mn-54 and Na-22
GF-290-1x	1 µCi	37 kBq	Ba-133, Cd-109, Co-57, Co-60, Cs-137, Mn-54 and Na-22
GF-290-10x	10 µCi	370 kBq	Ba-133, Cd-109, Co-57, Co-60, Cs-137, Mn-54 and Na-22

Gamma and X-Ray Standards

Gamma Standards—Type T

The type T plastic test tube is used in clinical instrument calibrations. Each polypropylene tube contains 0.75 mL of active epoxy with the balance of the tube filled with cold epoxy. Tube sizes are 2.95" high x 0.472" diameter (75 mm x 12 mm) or 2.17" high x 0.472" diameter (55 mm x 12 mm).



Window & Active Materials

Window	Nature of Active Materials
Not Applicable	Metallic Salts Distributed in Epoxy

Overall Dimensions

X	Height	Diameter	Active Volume
T1	2.17" (55 mm)	0.472" (12 mm)	0.75 mL
T2	2.95" (75 mm)	0.472" (12 mm)	0.75 mL

Figure 52-A: Type T

A1901

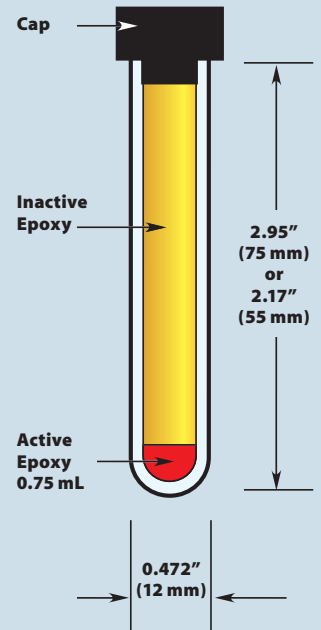

Gamma Standards—Type T

Catalog Number	Nuclide	Half-Life	Major Photon Emissions (keV)	Available Activities
GF-241-x	Americium-241	432.17 y	59.5 (36%), 11-20 (39.5%) Np L x-rays	5 nCi-10 µCi 185 Bq-370 kBq
GF-124-x	Antimony-124	60.20 d	602.7(97.9%), 722.8(10.9%), 1690.9(47.6%)	5 nCi-10 µCi 185 Bq-370 kBq
GF-125A-x	Antimony-125A	1007.7 d	428(29.7%), 464(10.5%), 601(17.7%), 607(5%), 636(11.2%), 27-32(75.1%) Te K x-rays	5 nCi-10 µCi 185 Bq-370 kBq
GF-133-x	Barium-133	3862 d	80(34.1%), 303(18.3%), 356(61.9%), 32-37(53.2%) Cs K x-rays	5 nCi-10 µCi 185 Bq-370 kBq
GF-007-x	Beryllium-7	On Request		
GF-207-x	Bismuth-207	1.16 x 10 ⁴ d	570(97.7%), 1064(74.5%), 9-15(32.5%), Pb L x-rays, 72-88(77.7%) Pb K x-rays	5 nCi-10 µCi 185 Bq-370 kBq
GF-109-x	Cadmium-109	462.6 d	88(3.6% from Ag-109 m), 22-26(99.4%) Ag K x-rays	50 nCi-10 µCi 1.85 kBq-370 kBq
GF-139-x	Cerium-139	137.640 d	33.03(22.8%), 33.4(41.9%), 165.9(79.9%), 33-39(80%) La x-rays	5 nCi-10 µCi 185 Bq-370 kBq
GF-141-x	Cerium-141	32.5 d	36.0(9.1%), 35.6(5%), 145.4(48.4%), 352.42(17%), Pr x-rays	— —
GF-134-x	Cesium-134	754.28 d	563(8.4%), 569(15.4%), 605(97.6%), 796(85.4%)	5 nCi-10 µCi 185 Bq-370 kBq
GF-137-x	Cesium-137	30.17 y	662(85.1% from Ba-137), 32-37(7.2%) Ba K x-rays	5 nCi-10 µCi 185 Bq-370 kBq
GF-051-x	Chromium-51	27.706 d	320(9.86%), 4.9-5.4(22.8%) V K x-rays	25 nCi-10 µCi 925 Bq-370 kBq

Gamma Standards—Type T						
Catalog Number	Nuclide	Half-Life	Major Photon Emissions (keV)	Available Activities		
GF-056-x	Cobalt-56	77.31 d	846.8(99.9%), 1238(66.1%), 1771(15.5%), 2035(7.8%), 2598(17%), 3253(7.6%), others up to 3452	10 nCi-10 µCi	370 Bq-370 kBq	
GF-057-x	Cobalt-57	271.79 d	14(9.2%), 122(85.6%), 136.5(10.7%), 6.4-7.1(57.9%) Fe K x-rays	5 nCi-10 µCi	185 Bq-370 kBq	
GF-058-x	Cobalt-58	70.86 d	810(99.5%), 6.4-7.1(26.7%) Fe K x-rays	5 nCi-10 µCi	185 Bq-370 kBq	
GF-060-x	Cobalt-60	5.272 y	1173(100%), 1333(100%)	5 nCi-10 µCi	185B q-370 kBq	
GGF-152-x	Europium-152	4933 d	122-1408, 40-47(74%) Sm +Gd x-rays	25 nCi-10 µCi	925 Bq-370 kBq	
GF-154-x	Europium-154	3136.8 d	123-1597, 42-50(25.6%) Gd x-rays	25 nCi-10 µCi	925 Bq-370 kBq	
GF-155-x	Europium-155	1770 d	87(34%), 105(20.6%), 42-50(24.0%), Gd K x-rays	10 nCi-10 µCi	370 Bq-370 kBq	
GF-153-x	Gadolinium-153	242 d	97(29.5%), 103(21.1%), 40-49(122%) Eu K x-rays	10 nCi-10 µCi	370 Bq-370 kBq	
F-068-x	Germanium-68	270.8 d	511(178%), 1077(3.2%) from Ga-68, 9.2-10.4(44.1%) Ga K x-rays, 8.6-9.6(4.7%) Zn K x-rays	100 nCi-10 µCi	3.7 kBq-370 kBq	
GF-166-x	Holmium-166m	1200 y	81-1427, 48-58(37.6%) Er K x-rays	10 nCi-1 µCi	370 Bq-37 kBq	
GF-125-x	Iodine-125	59.43 d	35(6.58%), 27-32(139%) Te K x-rays	10 nCi-10 µCi	370 Bq-370 kBq	
GF-129-x	Iodine-129	1.5 x 10 ⁷ y	40(7.5%), 29-35(70.4%) Xe K x-rays	50 nCi-1 µCi	1.85 kBq-37 kBq	
GF-059-x	Iron-59	44.51 d	1099(56.3%), 1292(43.7%)	5 nCi-10 µCi	185 Bq-370 kBq	
GF-054-x	Manganese-54	312.3 d	835(100%), 5.4-5.9(25.6%) Cr K x-rays	5 nCi-10 µCi	185 Bq-370 kBq	
GF-203-x	Mercury-203	46.595 d	279.2(81.5%)	10 nCi-10 µCi	370 Bq-370 kBq	
GF-046-x	Scandium-46	83.79 d	889(99.9%), 1121(99.9%)	5 nCi-10 µCi	185 Bq-370 kBq	
GF-075-x	Selenium-75	119.64 d	121(17.1%), 136(58.8%), 265(59%), 280(25%), 10.5-12.0(56.8%) As K x-rays	5 nCi-10 µCi	185B q-370 kBq	
GF-110-x	Silver-110m	249.8 d	657.8(94.4%), 884.6(72.6%)	5 nCi-10 µCi	185 Bq-370 kBq	
GF-131-x	Simulated I-131	~5 y	356 (from Ba-133), 662 (from Cs-137/Ba-137)	50 nCi-10 µCi	1.85 kBq-370 kBq	
GF-022-x	Sodium-22	950.8 d	511(178%), 1275(100%)	5 nCi-10 µCi	185 Bq-370 kBq	
GF-085-x	Strontium-85	64.849 d	514(98.4%), 13.3-15.3(58.7%) Rb K x-rays	5 nCi-10 µCi	185 Bq-370 kBq	
GF-113-x	Tin-113	115.09 d	392(64% from In-113 m), 24-28(96.8%) In K x-rays	5 nCi-10 µCi	185 Bq-370 kBq	
GF-088-x	Yttrium-88	106.630 d	898(94%), 1836(99.4%), 14.1-16.2(61.6%) Sr K x-rays	5 nCi-10 µCi	185 Bq-370 kBq	
GF-065-x	Zinc-65	244.26 d	1116(50.6%), 8.0-8.9(38.7%) Cu K x-rays	5 nCi-10 µCi	185 Bq-370 kBq	
GF-095-x	Zirconium-95/Nb-95	64.02 d	724(44.1%), 757(54.5%)	10 nCi-10 µCi	370 Bq-370 kBq	

Gamma Sets—Type T			
Catalog Number	Available Activities		Sets Consist Of
GF-290-0.1x	0.1 µCi	3.7 kBq	Ba-133, Cd-109, Co-57, Co-60, Cs-137, Mn-54 and Na-22
GF-290-1x	1 µCi	37 kBq	Ba-133, Cd-109, Co-57, Co-60, Cs-137, Mn-54 and Na-22
GF-290-10x	10 µCi	370 kBq	Ba-133, Cd-109, Co-57, Co-60, Cs-137, Mn-54 and Na-22